

# MONROE MAGNUM™

PTFE coated bushing to reduce friction during operation between the rod and rod guide, improving durability

Robust hydraulic lock-out design to prevent over-extension of the suspension, top-out of the piston and averts damage to the seal assembly

Thicker pressure tube provides the ability to handle more severe road condition

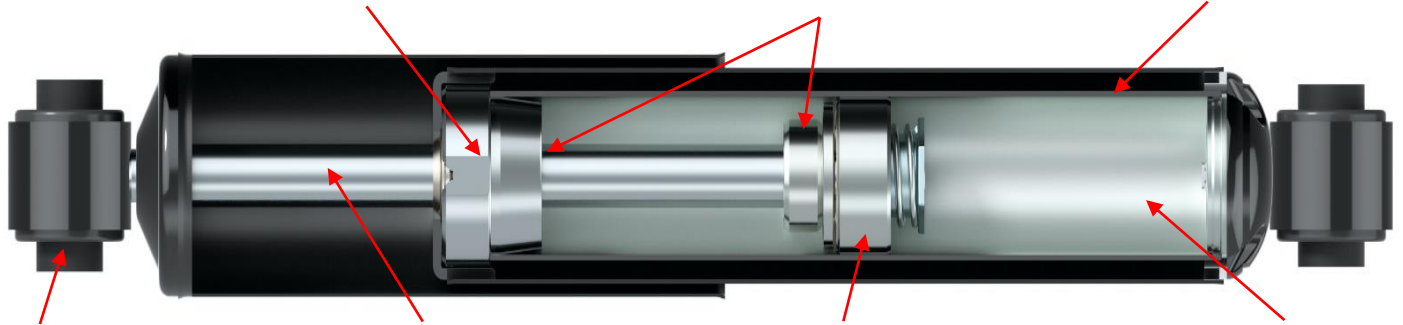

Shouldered bushing and bonded bushing with sleeve designs prevent bushing walkout for improved quality and durability

Large diameter nitrocarburized rod provides better compression control and side-load strength

Sintered steel piston design for more precise dimensions, requiring no additional components, for improved durability and an exceptional fit

Large 1.75" bore size gives accessibility to finer tune the valving by allowing more hydraulic fluid to dissipate heat for better vehicle control



Monroe Part	OE Part	% of Sales L12 Mths	% Sales Cumm	Brand Description
65490	1613957000, 1613957003, 1616591000, 1620716000	35.77%	36%	MAGNUM 65 SHOCK
65148	101380900, 1012396000, 1013634000, 1013684000, 1013809000	19.32%	55%	MAGNUM 65 SHOCK
65103	1012030002, 1012032000, 1012032001, 1012032002, 1012032003, 1012032004, 1012046000	5.01%	60%	MAGNUM 65 SHOCK
66118	1830378, 1830378000, 1832999000, 1860295000	3.18%	63%	MAGNUM CAB SHOCK
66893	1614759000	2.93%	66%	MAGNUM 60 SHOCK
66122	1832999001, 1841762002, 1860764000, 1860695000, 814903003528	2.01%	68%	MAGNUM CAB SHOCK
65492	3688615C1	1.44%	70%	MAGNUM 65 SHOCK
65528	C711011	1.30%	71%	MAGNUM 65 SHOCK
65416	1614759000	1.27%	72%	MAGNUM 65 SHOCK
65495	C711002	1.21%	73%	MAGNUM 65 SHOCK
66147	1829846000, 1829846001	1.10%	75%	MAGNUM CAB SHOCK
65405	AMS650405	1.08%	76%	MAGNUM 65 SHOCK
65140	61300224	1.00%	77%	MAGNUM 65 SHOCK
65419	90044162	1.00%	78%	MAGNUM 65 SHOCK
66608	90044162	0.99%	79%	MAGNUM 60 SHOCK
65101	665659	0.92%	80%	MAGNUM 65 SHOCK
65408	1613947000	0.62%	80%	MAGNUM 65 SHOCK
65435	1012542000	0.62%	81%	MAGNUM 65 SHOCK
65489	1614259000, 1615675000, 1616577000, 1616827000	0.61%	81%	MAGNUM 65 SHOCK
65102	B711002	0.56%	82%	MAGNUM 65 SHOCK